

JXiQ™ ASME COMPLIANT
GAS POOL & SPA HEATER

Jandy®



THE **SMARTEST** WAY TO HEAT YOUR COMMERCIAL POOL AND SPA



OFFICIAL
POOL
EQUIPMENT
SUPPLIER



JXiQ™
GAS HEATER



The JXiQ™ ASME Compliant Gas Pool & Spa Heater for Commercial use takes the guess work out of pool heating making it easy to use, install and service.

Built with the brawn to withstand the high-use demands of commercial properties, ASME compliant JXiQ heaters are ultra-compact and constructed with bronze headers and thicker-walled copper fin tubes.

Commercial Grade Models

Small but strong enough to handle the rigors of non-residential use, ASME compliant JXiQ heaters feature burly bronze headers and 30%¹ thicker-walled, robust copper or cupronickel heat exchanger tubes and corrosion-resistant bronze headers to meet the high stresses of commercial installations

¹30% thicker than other models.

Energy-Efficient Heating

84% thermal efficiency rating² and low-NO_x design surpasses strict DOE Energy Efficiency requirements

²84% Thermal Efficiency applies to All Models except 260K BTU Natural Gas model with Cupronickel heat exchanger which is 83%, see table for complete model listing.

- Low Gas Pressure Sensor**
 Ensures there's enough gas pressure to safely ignite
- Optimize Flow**
 Measures temperature rise between the inlet and outlet to optimize flow and avoid heat exchanger failures
- Auto-Sensing Power Input**
 Automatically adjusts to supplied power when installed — no cards to flip and no wires to change
- Largest Display in the Industry**
 Digital display is 50% larger than before and capable of showing 80 characters
- Best Drop-In Option**
 Plumbing flexibility for quick MasterTemp® and Max-E Therm® replacement that requires no plumbing adjustments
- Flexible Installation. Easy Servicing.**
 Top easily removed and rotated 180 degrees for increased accessibility; includes flip up electrical panel
- Keeps Critters Out**
 No more chewed up wires. The JXiQ is made with a fully enclosed shell to protect against rodent intrusion and damage
- Ultra-Compact Lightweight Design**
 Fits on a 2' x 2' pad and is 38% lighter with a 28% smaller footprint*

*Compared to popular competitor models.

ASME® Compliant JXiQ Heaters

Part No.	Firing Rate	Gas Type	Heat Exchanger	Thermal Efficiency	Weight	Vent Diameter*	Min. GPM	Max. GPM
JXiQ260NC	260K BTU	Natural Gas	Copper	84%	163 lbs.	7" (18 cm)	30	100
JXiQ260PC	260K BTU	Propane	Copper	84%	163 lbs.	7" (18 cm)	30	100
JXiQ400NC	400K BTU	Natural Gas	Copper	84%	168 lbs.	8" (20 cm)	30	100
JXiQ400PC	400K BTU	Propane	Copper	84%	168 lbs.	8" (20 cm)	30	100
JXiQ260NS	260K BTU	Natural Gas	Cupronickel	83%	163 lbs.	7" (18 cm)	30	100
JXiQ260PS	260K BTU	Propane	Cupronickel	84%	163 lbs.	7" (18 cm)	30	100
JXiQ400NS	400K BTU	Natural Gas	Cupronickel	84%	168 lbs.	8" (20 cm)	30	100
JXiQ400PS	400K BTU	Propane	Cupronickel	84%	168 lbs.	8" (20 cm)	30	100

*Minimum vent pipe size for Category I installations.

DIMENSIONS

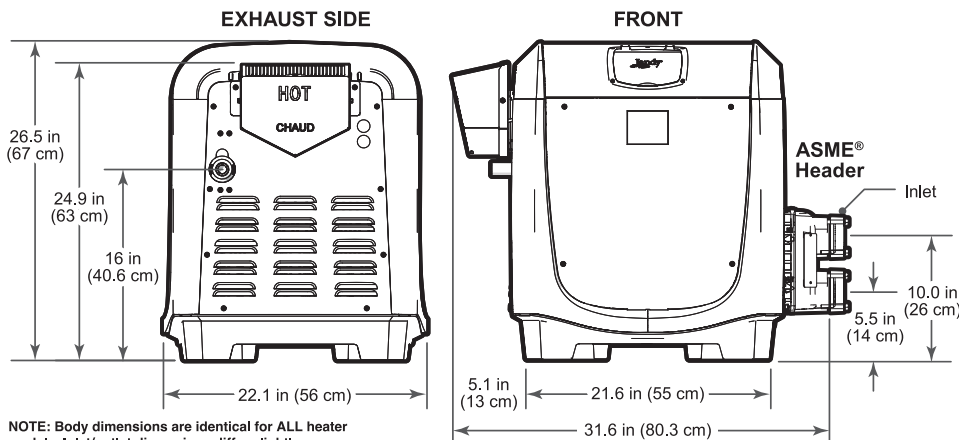

1-Year Commercial limited Warranty

A Fluidra Brand | Jandy.com | 1.800.822.7933

TRADE SERIES
EXCLUSIVE



87644_SL